

nta

Question Paper Name : B Tech 20072021 Shift 2
Subject Name : B TECH
Creation Date : 2021-07-25 17:28:53
Duration : 180
Total Marks : 300
Display Marks: Yes

B TECH

Group Number : 1
Group Id : 864351235
Group Maximum Duration : 0
Group Minimum Duration : 180
Show Attended Group? : No
Edit Attended Group? : No
Break time : 0
Group Marks : 300
Is this Group for Examiner? : No

Physics Section A

Section Id : 864351848
Section Number : 1
Section type : Online
Mandatory or Optional : Mandatory

Number of Questions :	20
Number of Questions to be attempted :	20
Section Marks :	80
Enable Mark as Answered Mark for Review and Clear Response :	Yes
Sub-Section Number :	1
Sub-Section Id :	8643511075
Question Shuffling Allowed :	Yes

Question Type : MCQ Is Question Mandatory : No

Correct Marks : 4 Wrong Marks : 1

A simple pendulum of mass ' m ', length ' l ' and charge ' $+q$ ' suspended in the electric field produced by two conducting parallel plates as shown. The value of deflection of pendulum in equilibrium position will be :

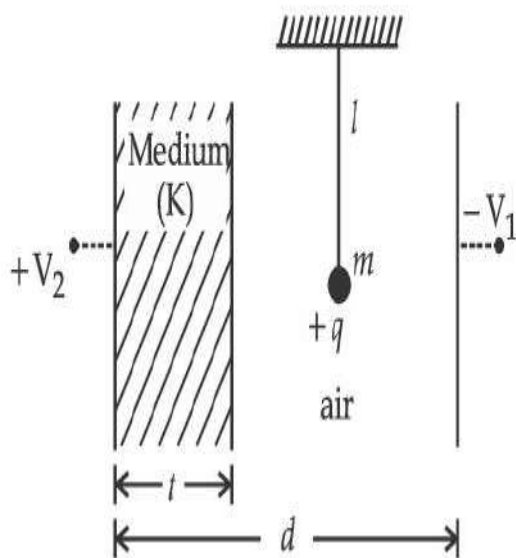

Options :

1. $\tan^{-1} \left[\frac{q}{mg} \times \frac{C_1(V_1 + V_2)}{(C_1 + C_2)(d - t)} \right]$

2. $\tan^{-1} \left[\frac{q}{mg} \times \frac{C_2(V_1 + V_2)}{(C_1 + C_2)(d - t)} \right]$

3.
$$\tan^{-1} \left[\frac{q}{mg} \times \frac{C_1(V_2 - V_1)}{(C_1 + C_2)(d - t)} \right]$$

4.
$$\tan^{-1} \left[\frac{q}{mg} \times \frac{C_2(V_2 - V_1)}{(C_1 + C_2)(d - t)} \right]$$

Question Type : MCQ Is Question Mandatory : No

Correct Marks : 4 Wrong Marks : 1

Find the truth table for the function Y of A and B represented in the following figure.

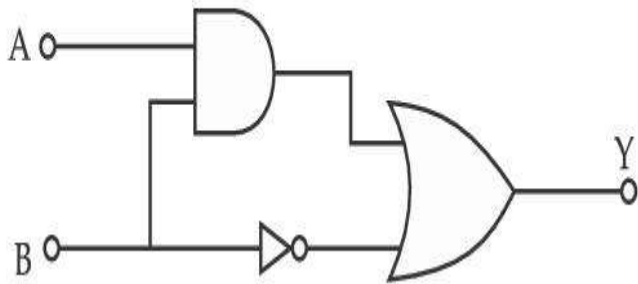

Options :

A	B	Y
0	0	0
0	1	1
1	0	0
1	1	0

1.

2.

A	B	Y
0	0	1
0	1	0
1	0	1
1	1	1

3.

A	B	Y
0	0	0
0	1	1
1	0	1
1	1	1

4.

A	B	Y
0	0	0
0	1	0
1	0	0
1	1	1

Question Type : MCQ Is Question Mandatory : No

Correct Marks : 4 Wrong Marks : 1

A particle of mass M originally at rest is subjected to a force whose direction is constant but magnitude varies with time according to the relation

$$F = F_0 \left[1 - \left(\frac{t - T}{T} \right)^2 \right]$$

Where F_0 and T are constants. The force acts only for the time interval $2T$. The velocity v of the particle after time $2T$ is :

Options :

1. $F_0 T / 3M$
2. $4F_0 T / 3M$
3. $F_0 T / 2M$
4. $2F_0 T / M$

Question Type : MCQ Is Question Mandatory : No

Correct Marks : 4 Wrong Marks : 1

Match List I with List II.

List I

- (a) Capacitance, C
- (b) Permittivity of free space, ϵ_0
- (c) Permeability of free space, μ_0
- (d) Electric field, E

List II

- (i) $M^1 L^1 T^{-3} A^{-1}$
- (ii) $M^{-1} L^{-3} T^4 A^2$
- (iii) $M^{-1} L^{-2} T^4 A^2$
- (iv) $M^1 L^1 T^{-2} A^{-2}$

Choose the correct answer from the options given below :

Options :

1. (a) \rightarrow (iii), (b) \rightarrow (iv), (c) \rightarrow (ii), (d) \rightarrow (i)
2. (a) \rightarrow (iv), (b) \rightarrow (ii), (c) \rightarrow (iii), (d) \rightarrow (i)

3. (a) → (iii), (b) → (ii), (c) → (iv), (d) → (i)

4. (a) → (iv), (b) → (iii), (c) → (ii), (d) → (i)

Question Type : MCQ Is Question Mandatory : No

Correct Marks : 4 Wrong Marks : 1

One mole of an ideal gas is taken through an adiabatic process where the temperature rises from 27°C to 37°C. If the ideal gas is composed of polyatomic molecule that has 4 vibrational modes, which of the following is true ?

$$[R = 8.314 \text{ J mol}^{-1} \text{ K}^{-1}]$$

Options :

1. work done by the gas is close to 582 J

2. work done on the gas is close to 582 J

3. work done by the gas is close to 332 J

4. work done on the gas is close to 332 J

Question Type : MCQ Is Question Mandatory : No

Correct Marks : 4 Wrong Marks : 1

Given below is the plot of a potential energy function $U(x)$ for a system, in which a particle is in one dimensional motion, while a conservative force $F(x)$ acts on it. Suppose that $E_{\text{mech}} = 8 \text{ J}$, the incorrect statement for this system is :

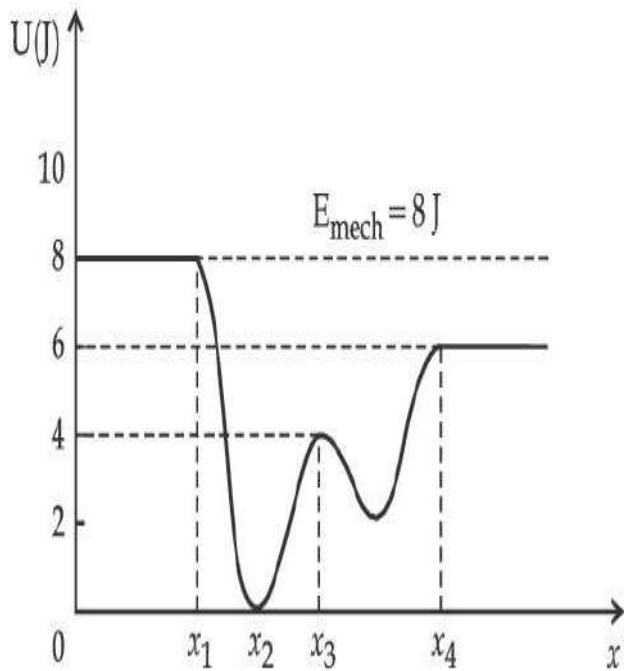

[where K.E. = kinetic energy]

Options :

1. at $x = x_2$, K.E. is greatest and the particle is moving at the fastest speed.
2. at $x < x_1$, K.E. is smallest and the particle is moving at the slowest speed.
3. at $x > x_4$, K.E. is constant throughout the region.
4. at $x = x_3$, K.E. = 4 J.

Question Type : MCQ Is Question Mandatory : No

Correct Marks : 4 Wrong Marks : 1

Consider the following statements :

- A. Atoms of each element emit characteristics spectrum.
- B. According to Bohr's Postulate, an electron in a hydrogen atom, revolves in a certain stationary orbit.
- C. The density of nuclear matter depends on the size of the nucleus.
- D. A free neutron is stable but a free proton decay is possible.
- E. Radioactivity is an indication of the instability of nuclei.

Choose the correct answer from the options given below :

Options :

1. A, B and E only
2. A, C and E only
3. B and D only
4. A, B, C, D and E

Question Type : MCQ Is Question Mandatory : No

Correct Marks : 4 Wrong Marks : 1

A raindrop with radius $R = 0.2$ mm falls from a cloud at a height $h = 2000$ m above the ground. Assume that the drop is spherical throughout its fall and the force of buoyance may be neglected, then the terminal speed attained by the raindrop is :

[Density of water $f_w = 1000 \text{ kg m}^{-3}$

and Density of air $f_a = 1.2 \text{ kg m}^{-3}$,

$g = 10 \text{ m/s}^2$

Coefficient of viscosity of air $= 1.8 \times 10^{-5} \text{ Nsm}^{-2}$]

Options :

1. 250.6 ms^{-1}

2. 4.94 ms^{-1}

3. 14.4 ms^{-1}

4. 43.56 ms^{-1}

Question Type : MCQ Is Question Mandatory : No

Correct Marks : 4 Wrong Marks : 1

A physical quantity 'y' is represented by the formula $y = m^2 r^{-4} g^x l^{\frac{3}{2}}$

If the percentage errors found in y, m, r, l and g are 18, 1, 0.5, 4 and p respectively, then find the value of x and p .

Options :

1. 4 and ± 3

2. 5 and ± 2

3. 8 and ± 2

4. $\frac{16}{3}$ and $\pm \frac{3}{2}$

Question Type : MCQ Is Question Mandatory : No

Correct Marks : 4 Wrong Marks : 1

Two Carnot engines A and B operate in series such that engine A absorbs heat at T_1 and rejects heat to a sink at temperature T . Engine B absorbs half of the heat rejected by Engine A and rejects heat to the sink at T_3 . When workdone in both the cases is equal, the value of T is :

Options :

1. $\frac{2}{3}T_1 + \frac{1}{3}T_3$

2. $\frac{3}{2}T_1 + \frac{1}{3}T_3$

3. $\frac{2}{3}T_1 + \frac{3}{2}T_3$

4. $\frac{1}{3}T_1 + \frac{2}{3}T_3$

Question Type : MCQ Is Question Mandatory : No

Correct Marks : 4 Wrong Marks : 1

The planet Mars has two moons, if one of them has a period 7 hours, 30 minutes and an orbital radius of 9.0×10^3 km. Find the mass of Mars.

$$\left\{ \text{Given } \frac{4\pi^2}{G} = 6 \times 10^{11} \text{ N}^{-1} \text{ m}^{-2} \text{ kg}^2 \right\}$$

Options :

1. $5.96 \times 10^{19} \text{ kg}$

2. $3.25 \times 10^{21} \text{ kg}$

3. $6.00 \times 10^{23} \text{ kg}$

4. $7.02 \times 10^{25} \text{ kg}$

Question Type : MCQ Is Question Mandatory : No

Correct Marks : 4 Wrong Marks : 1

An object of mass 0.5 kg is executing simple harmonic motion. Its amplitude is 5 cm and time period (T) is 0.2 s. What will be the potential energy of the object at an instant $t = \frac{T}{4}$ s starting from mean position. Assume that the initial phase of the oscillation is zero.

Options :

1. 6.2×10^{-3} J
2. 1.2×10^3 J
3. 0.62 J
4. 6.2×10^3 J

Question Type : MCQ Is Question Mandatory : No

Correct Marks : 4 Wrong Marks : 1

An automobile of mass ' m ' accelerates starting from origin and initially at rest, while the engine supplies constant power P. The position is given as a function of time by :

Options :

1. $\left(\frac{9P}{8m}\right)^{\frac{1}{2}} t^{\frac{3}{2}}$
- 2.

$$\left(\frac{8P}{9m}\right)^{\frac{1}{2}} t^{\frac{2}{3}}$$

3. $\left(\frac{8P}{9m}\right)^{\frac{1}{2}} t^{\frac{3}{2}}$

4. $\left(\frac{9m}{8P}\right)^{\frac{1}{2}} t^{\frac{3}{2}}$

Question Type : MCQ Is Question Mandatory : No

Correct Marks : 4 Wrong Marks : 1

Figure A and B show two long straight wires of circular cross-section (a and b with $a < b$), carrying current I which is uniformly distributed across the cross-section. The magnitude of magnetic field B varies with radius r and can be represented as :

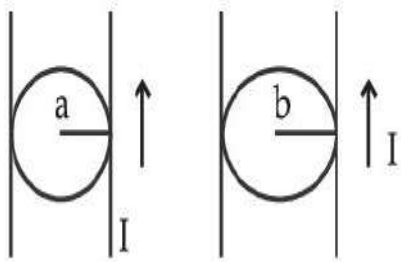
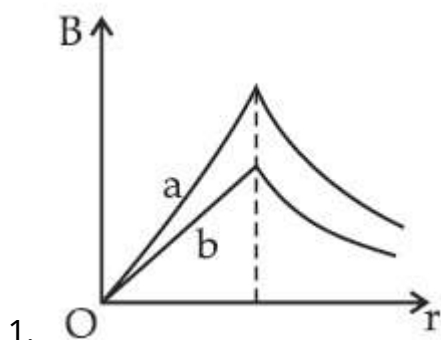
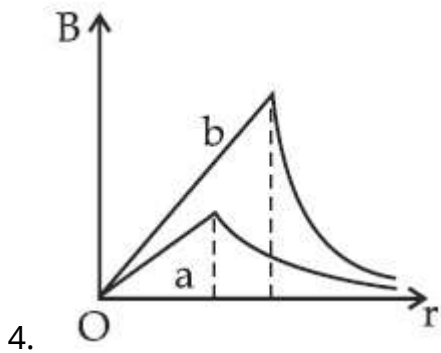
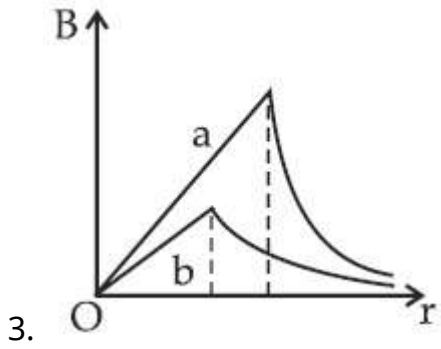
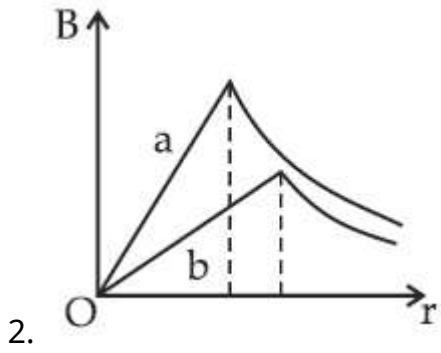

Fig. A

Fig. B

Options :





Question Type : MCQ Is Question Mandatory : No

Correct Marks : 4 Wrong Marks : 1

Two identical particles of mass 1 kg each go round a circle of radius R , under the action of their mutual gravitational attraction. The angular speed of each particle is :

Options :

1. $\sqrt{\frac{G}{2R^3}}$

2.

$$\frac{1}{2} \sqrt{\frac{G}{R^3}}$$

3. $\frac{1}{2R} \sqrt{\frac{1}{G}}$

4. $\sqrt{\frac{2G}{R^3}}$

Question Type : MCQ Is Question Mandatory : No

Correct Marks : 4 Wrong Marks : 1

An electron and proton are separated by a large distance. The electron starts approaching the proton with energy 3 eV. The proton captures the electron and forms a hydrogen atom in second excited state. The resulting photon is incident on a photosensitive metal of threshold wavelength 4000 Å. What is the maximum kinetic energy of the emitted photoelectron?

Options :

1. 3.3 eV

2. No photoelectron would be emitted

3. 7.61 eV

4. 1.41 eV

Question Type : MCQ Is Question Mandatory : No

Correct Marks : 4 Wrong Marks : 1

The expected graphical representation of the variation of angle of deviation ' δ ' with angle of incidence ' i ' in a prism is :

Options :

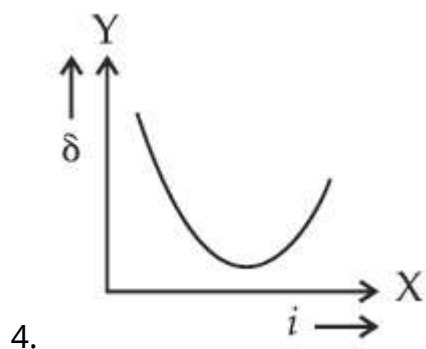
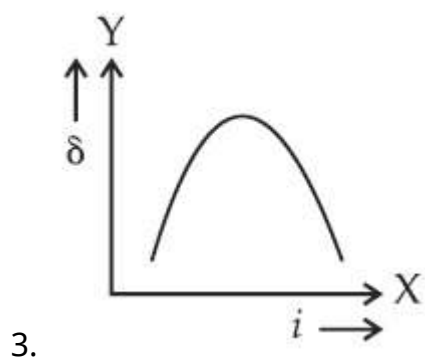
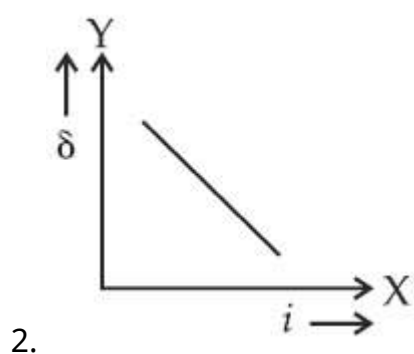
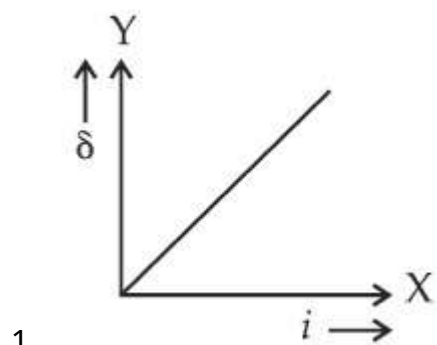

Question Type : MCQ Is Question Mandatory : No

Correct Marks : 4 Wrong Marks : 1

A $100\ \Omega$ resistance, a $0.1\ \mu\text{F}$ capacitor and an inductor are connected in series across a $250\ \text{V}$ supply at variable frequency. Calculate the value of inductance of inductor at which resonance will occur. Given that the resonant frequency is $60\ \text{Hz}$.

Options :

1. $7.03 \times 10^{-5}\ \text{H}$
2. $70.3\ \text{H}$
3. $0.70\ \text{H}$
4. $70.3\ \text{mH}$

Question Type : MCQ Is Question Mandatory : No

Correct Marks : 4 Wrong Marks : 1

The resistance of a conductor at 15°C is $16\ \Omega$ and at 100°C is $20\ \Omega$. What will be the temperature coefficient of resistance of the conductor ?

Options :

1. 0.003°C^{-1}
2. 0.010°C^{-1}
3. 0.033°C^{-1}
4. 0.042°C^{-1}

Question Type : MCQ Is Question Mandatory : No

Correct Marks : 4 Wrong Marks : 1

What will be the magnitude of electric field at point O as shown in figure ? Each side of the figure is l and perpendicular to each other ?

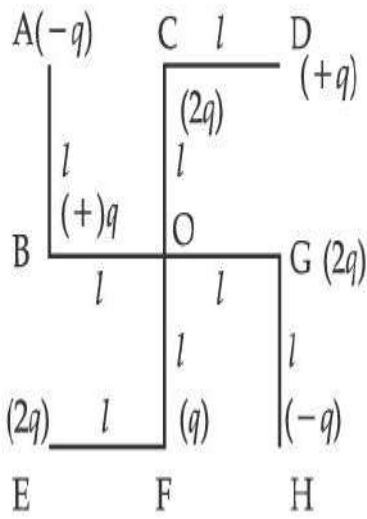

Options :

1. $\frac{1}{4\pi\epsilon_0} \frac{q}{l^2}$

2. $\frac{1}{4\pi\epsilon_0} \frac{2q}{2l^2} (\sqrt{2})$

3. $\frac{1}{4\pi\epsilon_0} \frac{q}{(2l^2)} (2\sqrt{2} - 1)$

4. $\frac{q}{4\pi\epsilon_0 (2l)^2}$

Physics Section B

Section Id :

864351849

Section Number :

2

Section type :	Online
Mandatory or Optional :	Mandatory
Number of Questions :	10
Number of Questions to be attempted :	5
Section Marks :	20
Enable Mark as Answered Mark for Review and Clear Response :	Yes
Sub-Section Number :	1
Sub-Section Id :	8643511076
Question Shuffling Allowed :	Yes

Question Type : SA

Correct Marks : 4 Wrong Marks : 0

The maximum amplitude for an amplitude modulated wave is found to be 12 V while the minimum amplitude is found to be 3 V. The modulation index is $0.6x$ where x is _____.

Response Type : Numeric

Evaluation Required For SA : Yes

Show Word Count : Yes

Answers Type : Equal

Text Areas : PlainText

Possible Answers :

1

Question Type : SA

Correct Marks : 4 Wrong Marks : 0

For the circuit shown, the value of current at time $t=3.2$ s will be _____ A.

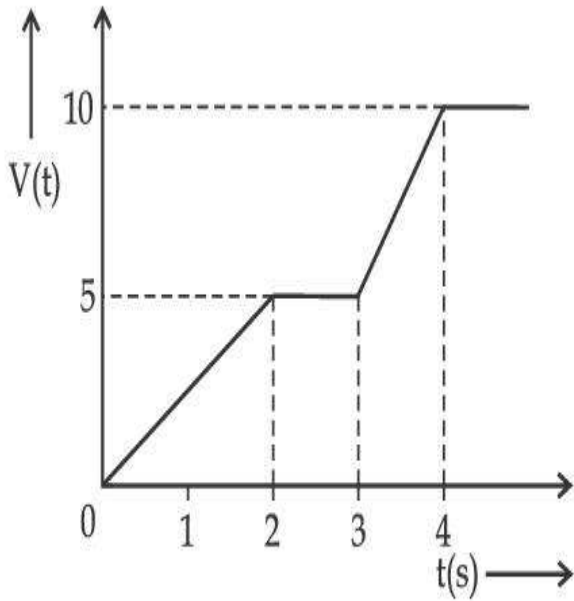

Figure 1

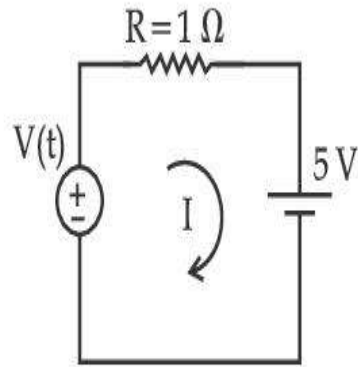

Figure 2

[Voltage distribution $V(t)$ is shown by Fig. (1) and the circuit is shown in Fig. (2)]

Response Type : Numeric

Evaluation Required For SA : Yes

Show Word Count : Yes

Answers Type : Equal

Text Areas : PlainText

Possible Answers :

1

Question Type : SA

Correct Marks : 4 **Wrong Marks :** 0

In the given figure the magnetic flux through the loop increases according to the relation $\phi_B(t) = 10t^2 + 20t$, where ϕ_B is in milliwebers and t is in seconds.

The magnitude of current through $R = 2 \Omega$ resistor at $t = 5$ s is _____ mA.

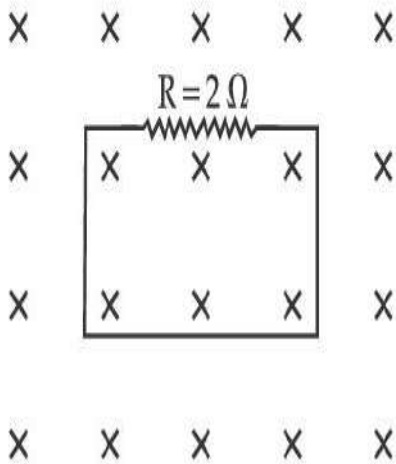

Response Type : Numeric

Evaluation Required For SA : Yes

Show Word Count : Yes

Answers Type : Equal

Text Areas : PlainText

Possible Answers :

1

Question Type : SA

Correct Marks : 4 **Wrong Marks :** 0

The K_α X-ray of molybdenum has wavelength 0.071 nm. If the energy of a molybdenum atom with a K electron knocked out is 27.5 keV, the energy of this atom when an L electron is knocked out will be _____ keV. (Round off to the nearest integer)

[$h = 4.14 \times 10^{-15}$ eVs, $c = 3 \times 10^8$ ms⁻¹]

Response Type : Numeric

Evaluation Required For SA : Yes

Show Word Count : Yes

Answers Type : Equal

Text Areas : PlainText

Possible Answers :

1

Question Type : SA

Correct Marks : 4 Wrong Marks : 0

The water is filled upto height of 12 m in a tank having vertical sidewalls. A hole is made in one of the walls at a depth ' h ' below the water level. The value of ' h ' for which the emerging stream of water strikes the ground at the maximum range is _____ m.

Response Type : Numeric

Evaluation Required For SA : Yes

Show Word Count : Yes

Answers Type : Equal

Text Areas : PlainText

Possible Answers :

1

Question Type : SA

Correct Marks : 4 Wrong Marks : 0

In the given figure, two wheels P and Q are connected by a belt B. The radius of P is three times as that of Q. In case of same rotational kinetic energy, the ratio of rotational inertias

$\left(\frac{I_1}{I_2}\right)$ will be $x : 1$. The value of x will be _____.

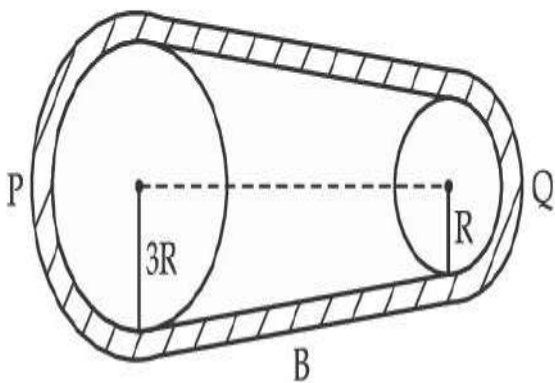

Response Type : Numeric

Evaluation Required For SA : Yes

Show Word Count : Yes

Answers Type : Equal

Text Areas : PlainText

Possible Answers :

1

Question Type : SA

Correct Marks : 4 **Wrong Marks :** 0

A small block slides down from the top of hemisphere of radius $R=3$ m as shown in the figure. The height ' h ' at which the block will lose contact with the surface of the sphere is _____ m.

(Assume there is no friction between the block and the hemisphere)

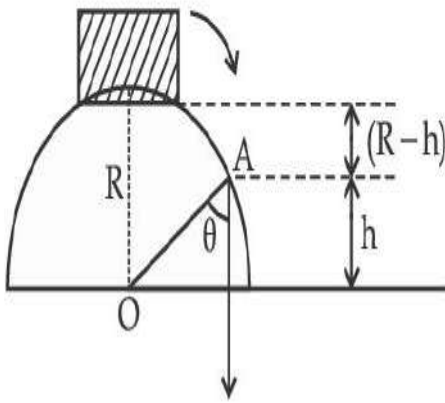

Response Type : Numeric

Evaluation Required For SA : Yes

Show Word Count : Yes

Answers Type : Equal

Text Areas : PlainText

Possible Answers :

1

Question Type : SA

Correct Marks : 4 **Wrong Marks :** 0

A swimmer wants to cross a river from point A to point B. Line AB makes an angle of 30° with the flow of river. Magnitude of velocity of the swimmer is same as that of the river. The angle θ with the line AB should be _____ $^\circ$, so that the swimmer reaches point B.

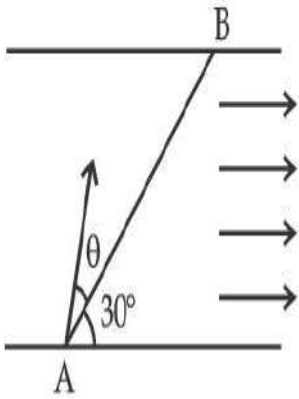

Response Type : Numeric

Evaluation Required For SA : Yes

Show Word Count : Yes

Answers Type : Equal

Text Areas : PlainText

Possible Answers :

1

Question Type : SA

Correct Marks : 4 **Wrong Marks :** 0

A particle executes simple harmonic motion represented by displacement function as

$$x(t) = A \sin(\omega t + \phi)$$

If the position and velocity of the particle at $t = 0$ s are 2 cm and 2ω cm s⁻¹ respectively, then its amplitude is $x\sqrt{2}$ cm where the value of x is _____.

Response Type : Numeric

Evaluation Required For SA : Yes

Show Word Count : Yes

Answers Type : Equal

Text Areas : PlainText

Possible Answers :

1

Question Type : SA

Correct Marks : 4 Wrong Marks : 0

The difference in the number of waves when yellow light propagates through air and vacuum columns of the same thickness is one. The thickness of the air column is _____ mm.

[Refractive index of air = 1.0003, wavelength of yellow light in vacuum = 6000 Å]

Response Type : Numeric

Evaluation Required For SA : Yes

Show Word Count : Yes

Answers Type : Equal

Text Areas : PlainText

Possible Answers :

1

Chemistry Section A

Section Id :	864351850
Section Number :	3
Section type :	Online
Mandatory or Optional :	Mandatory
Number of Questions :	20
Number of Questions to be attempted :	20
Section Marks :	80
Enable Mark as Answered Mark for Review and Clear Response :	Yes
Sub-Section Number :	1
Sub-Section Id :	8643511077
Question Shuffling Allowed :	Yes

Question Type : MCQ Is Question Mandatory : No

Correct Marks : 4 Wrong Marks : 1

Select the correct statements.

- (A) Crystalline solids have long range order.
- (B) Crystalline solids are isotropic.
- (C) Amorphous solids are sometimes called pseudo solids.
- (D) Amorphous solids soften over a range of temperatures.
- (E) Amorphous solids have a definite heat of fusion.

Choose the most appropriate answer from the options given below :

Options :

1. (A), (C), (D) only
2. (A), (B), (E) only
3. (C), (D) only
4. (B), (D) only

Question Type : MCQ Is Question Mandatory : No

Correct Marks : 4 Wrong Marks : 1

If the Thompson model of the atom was correct, then the result of Rutherford's gold foil experiment would have been :

Options :

1. All of the α -particles pass through the gold foil without decrease in speed.
2. α -Particles pass through the gold foil deflected by small angles and with reduced speed.

3. α -Particles are deflected over a wide range of angles.
4. All α -particles get bounced back by 180° .

Question Type : MCQ Is Question Mandatory : No

Correct Marks : 4 Wrong Marks : 1

Given below are two statements : one is labelled as **Assertion A** and the other is labelled as **Reason R**.

Assertion A : $\text{SO}_2(\text{g})$ is adsorbed to a larger extent than $\text{H}_2(\text{g})$ on activated charcoal.

Reason R : $\text{SO}_2(\text{g})$ has a higher critical temperature than $\text{H}_2(\text{g})$.

In the light of the above statements, choose the most appropriate answer from the options given below.

Options :

1. Both **A** and **R** are correct and **R** is the correct explanation of **A**.
2. Both **A** and **R** are correct but **R** is not the correct explanation of **A**.
3. **A** is correct but **R** is not correct.
4. **A** is not correct but **R** is correct.

Question Type : MCQ Is Question Mandatory : No

Correct Marks : 4 Wrong Marks : 1

The **CORRECT** order of first ionisation enthalpy is :

Options :

- 1.

Mg < Al < P < S

2. Mg < Al < S < P

3. Mg < S < Al < P

4. Al < Mg < S < P

Question Type : MCQ Is Question Mandatory : No

Correct Marks : 4 Wrong Marks : 1

The addition of silica during the extraction of copper from its sulphide ore

Options :

1. converts copper sulphide into copper silicate

2. reduces copper sulphide into metallic copper

3. converts iron oxide into iron silicate

4. reduces the melting point of the reaction mixture

Question Type : MCQ Is Question Mandatory : No

Correct Marks : 4 Wrong Marks : 1

The number of neutrons and electrons, respectively, present in the radioactive isotope of hydrogen is :

Options :

1. 2 and 1

2. 3 and 1
3. 2 and 2
4. 1 and 1

Question Type : MCQ Is Question Mandatory : No

Correct Marks : 4 Wrong Marks : 1

Match List - I with List - II :

List - I	List - II
(a) Li	(i) photoelectric cell
(b) Na	(ii) absorbent of CO ₂
(c) K	(iii) coolant in fast breeder nuclear reactor
(d) Cs	(iv) treatment of cancer
	(v) bearings for motor engines

Choose the **correct** answer from the options given below :

Options :

1. (a) - (iv), (b) - (iii), (c) - (i), (d) - (ii)
2. (a) - (v), (b) - (i), (c) - (ii), (d) - (iv)
3. (a) - (v), (b) - (ii), (c) - (iv), (d) - (i)
4. (a) - (v), (b) - (iii), (c) - (ii), (d) - (i)

Question Type : MCQ Is Question Mandatory : No

Correct Marks : 4 Wrong Marks : 1

Number of Cl=O bonds in chlorous acid, chloric acid and perchloric acid respectively are :

Options :

1. 1, 1 and 3
2. 3, 1 and 1
3. 1, 2 and 3
4. 4, 1 and 0

Question Type : MCQ Is Question Mandatory : No

Correct Marks : 4 Wrong Marks : 1

To an aqueous solution containing ions such as Al^{3+} , Zn^{2+} , Ca^{2+} , Fe^{3+} , Ni^{2+} , Ba^{2+} and Cu^{2+} was added conc. HCl, followed by H_2S .

The total number of cations precipitated during this reaction is/are :

Options :

1. 3
2. 2
3. 1
4. 4

Question Type : MCQ Is Question Mandatory : No

Correct Marks : 4 Wrong Marks : 1

Given below are two statements :

Statement I : $[\text{Mn}(\text{CN})_6]^{3-}$, $[\text{Fe}(\text{CN})_6]^{3-}$ and $[\text{Co}(\text{C}_2\text{O}_4)_3]^{3-}$ are d^2sp^3 hybridised.

Statement II : $[\text{MnCl}_6]^{3-}$ and $[\text{FeF}_6]^{3-}$ are paramagnetic and have 4 and 5 unpaired electrons, respectively.

In the light of the above statements, choose the **correct** answer from the options given below :

Options :

1. Both **statement I** and **statement II** are true
2. Both **statement I** and **statement II** are false
3. **Statement I** is correct but **statement II** is false
4. **Statement I** is incorrect but **statement II** is true

Question Type : MCQ Is Question Mandatory : No

Correct Marks : 4 Wrong Marks : 1

Match List - I with List - II :

List - I (compound)	List - II (effect/affected species)
(a) Carbon monoxide	(i) Carcinogenic
(b) Sulphur dioxide	(ii) Metabolized by pyrus plants
(c) Polychlorinated biphenyls	(iii) Haemoglobin
(d) Oxides of nitrogen	(iv) Stiffness of flower buds

Choose the **correct** answer from the options given below :

Options :

1. (a) - (iii), (b) - (iv), (c) - (i), (d) - (ii)
2. (a) - (iii), (b) - (iv), (c) - (ii), (d) - (i)
3. (a) - (iv), (b) - (i), (c) - (iii), (d) - (ii)
4. (a) - (i), (b) - (ii), (c) - (iii), (d) - (iv)

Question Type : MCQ Is Question Mandatory : No

Correct Marks : 4 Wrong Marks : 1

Which one of the following set of elements can be detected using sodium fusion extract ?

Options :

1. Nitrogen, Phosphorous, Carbon, Sulfur
2. Sulfur, Nitrogen, Phosphorous, Halogens
3. Phosphorous, Oxygen, Nitrogen, Halogens

4. Halogens, Nitrogen, Oxygen, Sulfur

Question Type : MCQ Is Question Mandatory : No

Correct Marks : 4 Wrong Marks : 1

Given below are two statements :

Statement I : Hyperconjugation is a permanent effect.

Statement II : Hyperconjugation in ethyl cation $(\text{CH}_3 - \overset{+}{\text{C}}\text{H}_2)$ involves the overlapping of $\text{C}_{\text{sp}^2} - \text{H}_{1\text{s}}$ bond with empty 2p orbital of other carbon.

Choose the correct option :

Options :

1. Both **statement I** and **statement II** are true
2. Both **statement I** and **statement II** are false
3. **Statement I** is correct but **statement II** is false
4. **Statement I** is incorrect but **statement II** is true

Question Type : MCQ Is Question Mandatory : No

Correct Marks : 4 Wrong Marks : 1

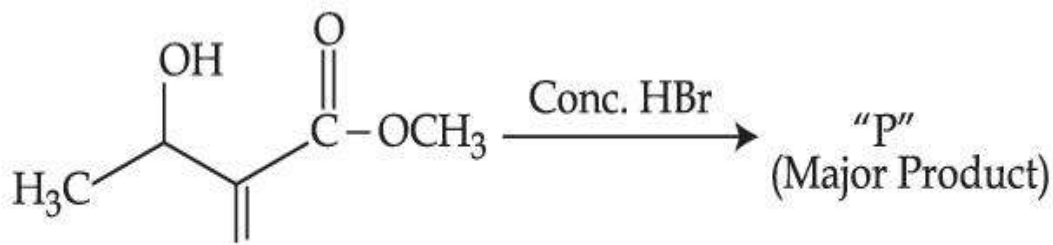

Consider the above reaction, the major product "P" formed is :

Options :

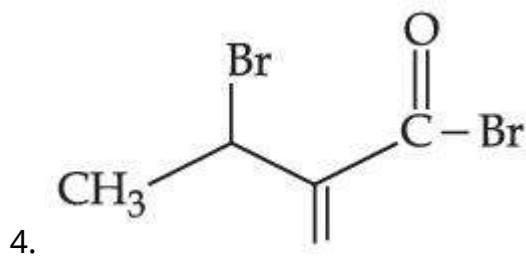
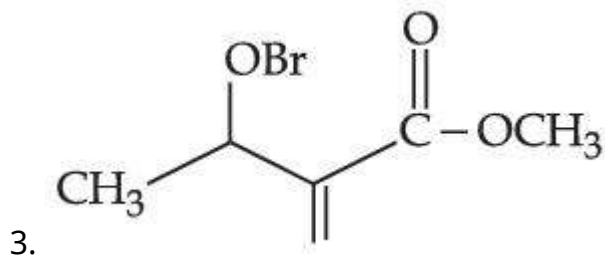
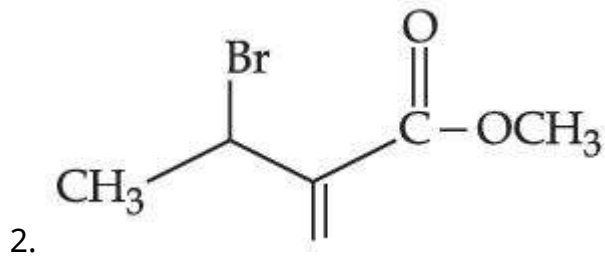
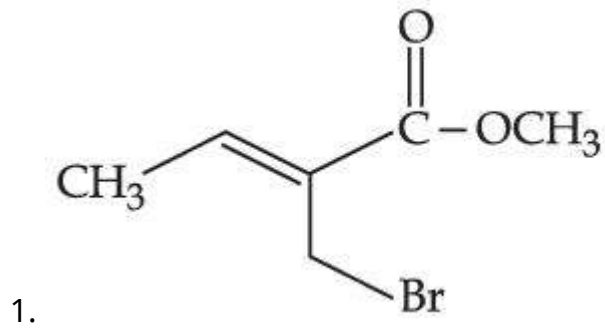

Question Type : MCQ Is Question Mandatory : No

Correct Marks : 4 Wrong Marks : 1

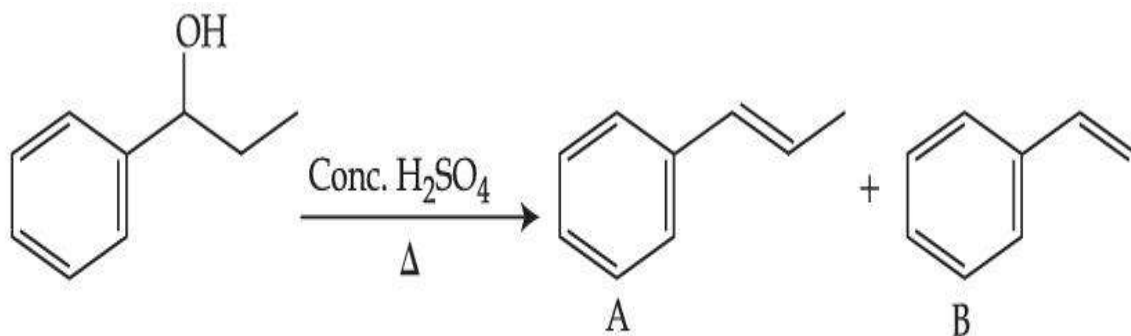

Consider the above reaction, and choose the correct statement :

Options :

1. Compound **A** will be the major product
2. Compound **B** will be the major product
3. Both compounds **A** and **B** are formed equally
4. The reaction is not possible in acidic medium

Question Type : MCQ Is Question Mandatory : No

Correct Marks : 4 Wrong Marks : 1

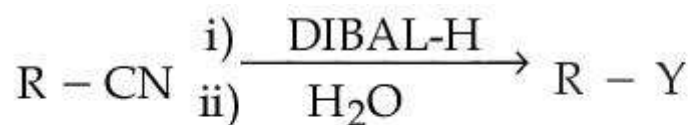

Consider the above reaction and identify "Y".

Options :

1. $-\text{COOH}$
2. $-\text{CH}_2\text{NH}_2$
3. $-\text{CHO}$

4. $-\text{CONH}_2$

Question Type : MCQ Is Question Mandatory : No

Correct Marks : 4 Wrong Marks : 1

The correct sequence of correct reagents for the following transformation is :

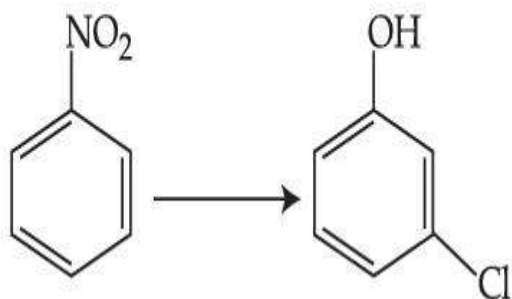

Options :

1. (i) $\text{Cl}_2, \text{FeCl}_3$ (ii) Fe, HCl (iii) $\text{NaNO}_2, \text{HCl}, 0^\circ\text{C}$ (iv) $\text{H}_2\text{O}/\text{H}^+$

2. (i) Fe, HCl (ii) $\text{NaNO}_2, \text{HCl}, 0^\circ\text{C}$ (iii) $\text{H}_2\text{O}/\text{H}^+$ (iv) $\text{Cl}_2, \text{FeCl}_3$

3. (i) Fe, HCl (ii) Cl_2, HCl (iii) $\text{NaNO}_2, \text{HCl}, 0^\circ\text{C}$ (iv) $\text{H}_2\text{O}/\text{H}^+$

4. (i) $\text{Cl}_2, \text{FeCl}_3$ (ii) $\text{NaNO}_2, \text{HCl}, 0^\circ\text{C}$ (iii) Fe, HCl (iv) $\text{H}_2\text{O}/\text{H}^+$

Question Type : MCQ Is Question Mandatory : No

Correct Marks : 4 Wrong Marks : 1

What is A in the following reaction ?

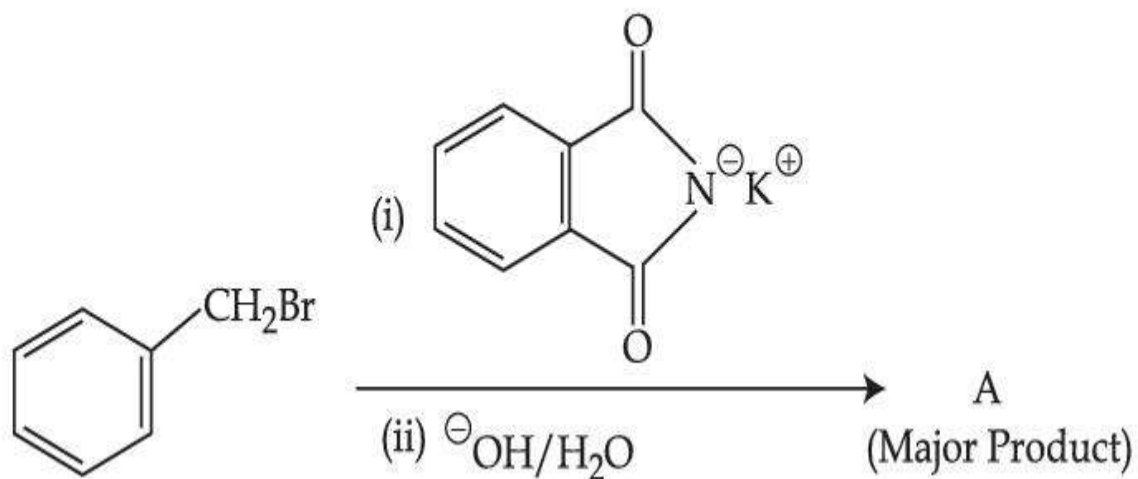

Options :

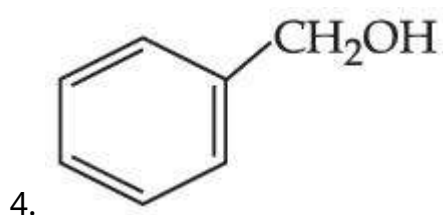
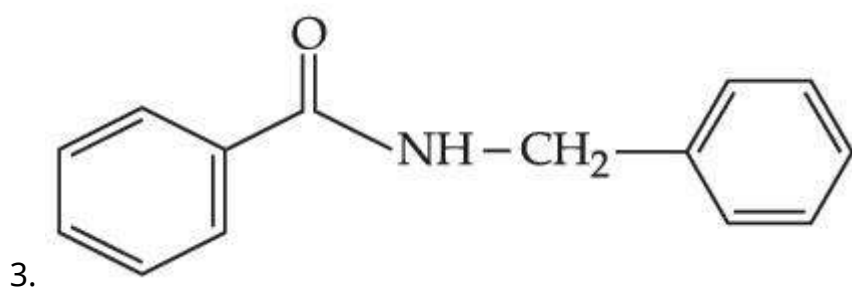
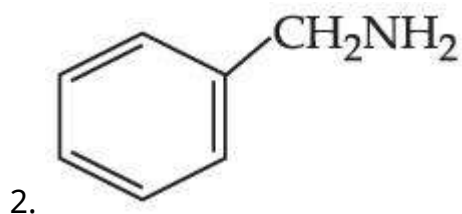
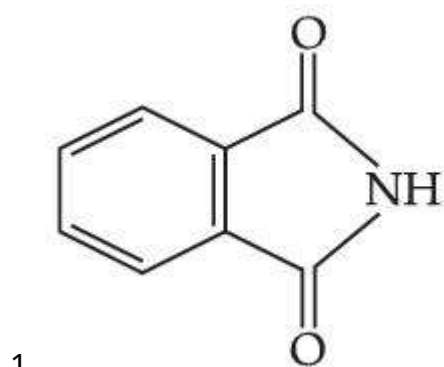

Question Type : MCQ Is Question Mandatory : No

Correct Marks : 4 Wrong Marks : 1

Given below are two statements :

Statement I : Penicillin is a bacteriostatic type antibiotic.

Statement II : The general structure of Penicillin is :

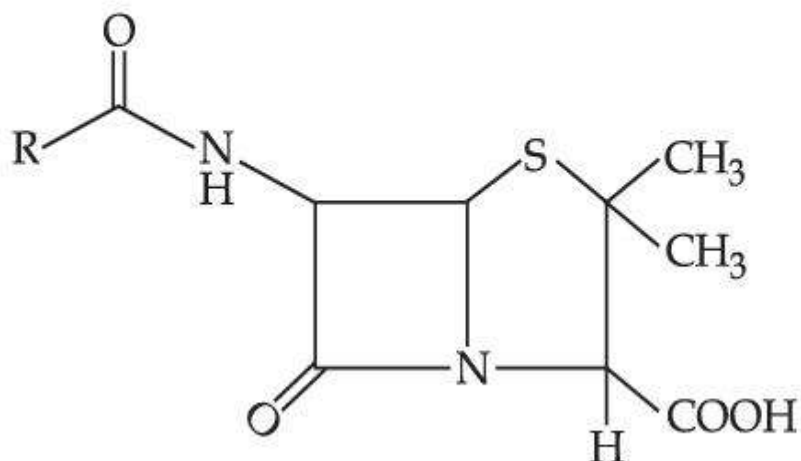

Choose the correct option :

Options :

1. Both **statement I** and **statement II** are true
2. Both **statement I** and **statement II** are false
3. **Statement I** is correct but **statement II** is false
4. **Statement I** is incorrect but **statement II** is true

Question Type : MCQ Is Question Mandatory : No

Correct Marks : 4 Wrong Marks : 1

Compound A gives D-Galactose and D-Glucose on hydrolysis. The compound A is :

Options :

1. Maltose

2. Lactose
3. Sucrose
4. Amylose

Chemistry Section B

Section Id :	864351851
Section Number :	4
Section type :	Online
Mandatory or Optional :	Mandatory
Number of Questions :	10
Number of Questions to be attempted :	5
Section Marks :	20
Enable Mark as Answered Mark for Review and Clear Response :	Yes
Sub-Section Number :	1
Sub-Section Id :	8643511078
Question Shuffling Allowed :	Yes

Question Type : SA

Correct Marks : 4 Wrong Marks : 0

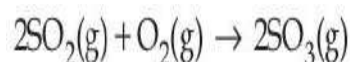

The above reaction is carried out in a vessel starting with partial pressures $P_{\text{SO}_2} = 250$ m bar, $P_{\text{O}_2} = 750$ m bar and $P_{\text{SO}_3} = 0$ bar. When the reaction is complete, the total pressure in the reaction vessel is _____ m bar. (Round off to the Nearest Integer).

Response Type : Numeric

Evaluation Required For SA : Yes

Show Word Count : Yes

Answers Type : Equal

Text Areas : PlainText

Possible Answers :

1

Question Type : SA

Correct Marks : 4 **Wrong Marks :** 0

The total number of electrons in all bonding molecular orbitals of O_2^{2-} is _____.

(Round off to the Nearest Integer).

Response Type : Numeric

Evaluation Required For SA : Yes

Show Word Count : Yes

Answers Type : Equal

Text Areas : PlainText

Possible Answers :

1

Question Type : SA

Correct Marks : 4 **Wrong Marks :** 0

When 400 mL of 0.2 M H_2SO_4 solution is mixed with 600 mL of 0.1 M NaOH solution, the increase in temperature of the final solution is _____ $\times 10^{-2}$ K. (Round off to the Nearest Integer).

[Use : $H^+(aq) + OH^-(aq) \rightarrow H_2O$: $\Delta_r H = -57.1 \text{ kJ mol}^{-1}$

Specific heat of $H_2O = 4.18 \text{ J K}^{-1} \text{ g}^{-1}$

density of $H_2O = 1.0 \text{ g cm}^{-3}$

Assume no change in volume of solution on mixing.]

Response Type : Numeric

Evaluation Required For SA : Yes

Show Word Count : Yes

Answers Type : Equal

Text Areas : PlainText

Possible Answers :

1

Question Type : SA

Correct Marks : 4 Wrong Marks : 0

In a solvent 50% of an acid HA dimerizes and the rest dissociates. The van't Hoff factor of the acid is _____ $\times 10^{-2}$. (Round off to the Nearest Integer).

Response Type : Numeric

Evaluation Required For SA : Yes

Show Word Count : Yes

Answers Type : Equal

Text Areas : PlainText

Possible Answers :

1

Question Type : SA

Correct Marks : 4 Wrong Marks : 0

The equilibrium constant for the reaction

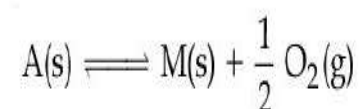

is $K_p = 4$. At equilibrium, the partial pressure of O_2 is _____ atm. (Round off to the Nearest Integer).

Response Type : Numeric

Evaluation Required For SA : Yes

Show Word Count : Yes

Answers Type : Equal

Text Areas : PlainText

Possible Answers :

1

Question Type : SA

Correct Marks : 4 Wrong Marks : 0

For the cell $\text{Cu(s)}|\text{Cu}^{2+}(\text{aq}) (0.1\text{ M})||\text{Ag}^{+}(\text{aq}) (0.01\text{ M})|\text{Ag(s)}$

the cell potential $E_1 = 0.3095\text{ V}$

For the cell $\text{Cu(s)}|\text{Cu}^{2+}(\text{aq}) (0.01\text{ M})||\text{Ag}^{+}(\text{aq}) (0.001\text{ M})|\text{Ag(s)}$

the cell potential = _____ $\times 10^{-2}\text{ V}$. (Round off to the Nearest Integer).

[Use : $\frac{2.303 RT}{F} = 0.059$]

Response Type : Numeric

Evaluation Required For SA : Yes

Show Word Count : Yes

Answers Type : Equal

Text Areas : PlainText

Possible Answers :

1

Question Type : SA

Correct Marks : 4 Wrong Marks : 0

For the first order reaction $A \rightarrow 2B$, 1 mole of reactant A gives 0.2 moles of B after 100 minutes. The half life of the reaction is _____ min. (Round off to the Nearest Integer).

[Use : $\ln 2 = 0.69$, $\ln 10 = 2.3$

Properties of logarithms : $\ln x^y = y \ln x$;

$$\ln\left(\frac{x}{y}\right) = \ln x - \ln y]$$

Response Type : Numeric

Evaluation Required For SA : Yes

Show Word Count : Yes

Answers Type : Equal

Text Areas : PlainText

Possible Answers :

1

Question Type : SA

Correct Marks : 4 Wrong Marks : 0

3 moles of metal complex with formula $\text{Co}(\text{en})_2\text{Cl}_3$ gives 3 moles of silver chloride on treatment with excess of silver nitrate. The secondary valency of Co in the complex is _____. (Round off to the Nearest Integer).

Response Type : Numeric

Evaluation Required For SA : Yes

Show Word Count : Yes

Answers Type : Equal

Text Areas : PlainText

Possible Answers :

1

Question Type : SA

Correct Marks : 4 Wrong Marks : 0

The dihedral angle in staggered form of Newman projection of 1,1,1-Trichloro ethane is _____ degree. (Round off to the Nearest Integer).

Response Type : Numeric

Evaluation Required For SA : Yes

Show Word Count : Yes

Answers Type : Equal

Text Areas : PlainText

Possible Answers :

1

Question Type : SA

Correct Marks : 4 Wrong Marks : 0

10.0 mL of 0.05 M KMnO_4 solution was consumed in a titration with 10.0 mL of given oxalic acid dihydrate solution. The strength of given oxalic acid solution is _____ $\times 10^{-2}$ g/L. (Round off to the Nearest Integer).

Response Type : Numeric

Evaluation Required For SA : Yes

Show Word Count : Yes

Answers Type : Equal

Text Areas : PlainText

Possible Answers :

1

Mathematics Section A

Section Id : 864351852

Section Number : 5

Section type : Online

Mandatory or Optional :	Mandatory
Number of Questions :	20
Number of Questions to be attempted :	20
Section Marks :	80
Enable Mark as Answered Mark for Review and Clear Response :	Yes
Sub-Section Number :	1
Sub-Section Id :	8643511079
Question Shuffling Allowed :	Yes

Question Type : MCQ Is Question Mandatory : No

Correct Marks : 4 Wrong Marks : 1

Let $f: \mathbf{R} \rightarrow \mathbf{R}$ be defined as

$f(x+y) + f(x-y) = 2f(x)f(y)$, $f\left(\frac{1}{2}\right) = -1$. Then, the value of

$$\sum_{k=1}^{20} \frac{1}{\sin(k) \sin(k + f(k))}$$
 is equal to :

Options :

1. $\sec^2(1) \sec(21) \cos(20)$
2. $\operatorname{cosec}^2(21) \cos(20) \cos(2)$
3. $\operatorname{cosec}^2(1) \operatorname{cosec}(21) \sin(20)$
4. $\sec^2(21) \sin(20) \sin(2)$

Question Type : MCQ Is Question Mandatory : No

Correct Marks : 4 Wrong Marks : 1

Let the mean and variance of the frequency distribution

$$x: \quad x_1=2 \quad x_2=6 \quad x_3=8 \quad x_4=9$$

$$f: \quad 4 \quad 4 \quad \alpha \quad \beta$$

be 6 and 6.8 respectively. If x_3 is changed from 8 to 7, then the mean for the new data will be :

Options :

1. $\frac{17}{3}$

2. 5

3. $\frac{16}{3}$

4. 4

Question Type : MCQ Is Question Mandatory : No

Correct Marks : 4 Wrong Marks : 1

Consider a circle C which touches the y -axis at $(0, 6)$ and cuts off an intercept $6\sqrt{5}$ on the x -axis. Then the radius of the circle C is equal to :

Options :

1. 8

2. $\sqrt{53}$

3. 9

4. $\sqrt{82}$

Question Type : MCQ Is Question Mandatory : No

Correct Marks : 4 Wrong Marks : 1

Two sides of a parallelogram are along the lines $4x + 5y = 0$ and $7x + 2y = 0$. If the equation of one of the diagonals of the parallelogram is $11x + 7y = 9$, then other diagonal passes through the point :

Options :

1. $(1, 2)$

2. $(2, 2)$

3. $(2, 1)$

4. $(1, 3)$

Question Type : MCQ Is Question Mandatory : No

Correct Marks : 4 Wrong Marks : 1

Let $f : [0, \infty) \rightarrow [0, 3]$ be a function defined by

$$f(x) = \begin{cases} \max \{ \sin t : 0 \leq t \leq x \}, & 0 \leq x \leq \pi \\ 2 + \cos x, & x > \pi \end{cases}$$

Then which of the following is true ?

Options :

1. f is not continuous exactly at two points in $(0, \infty)$

2. f is continuous everywhere but not differentiable exactly at two points in $(0, \infty)$
3. f is continuous everywhere but not differentiable exactly at one point in $(0, \infty)$
4. f is differentiable everywhere in $(0, \infty)$

Question Type : MCQ Is Question Mandatory : No

Correct Marks : 4 Wrong Marks : 1

Which of the following is the negation of the statement "for all $M > 0$, there exists $x \in S$ such that $x \geq M$ " ?

Options :

1. there exists $M > 0$, there exists $x \in S$ such that $x < M$
2. there exists $M > 0$, there exists $x \in S$ such that $x \geq M$
3. there exists $M > 0$, such that $x < M$ for all $x \in S$
4. there exists $M > 0$, such that $x \geq M$ for all $x \in S$

Question Type : MCQ Is Question Mandatory : No

Correct Marks : 4 Wrong Marks : 1

The area of the region bounded by $y - x = 2$ and $x^2 = y$ is equal to :

Options :

1. $\frac{2}{3}$

2. $\frac{4}{3}$

3. $\frac{9}{2}$

4. $\frac{16}{3}$

Question Type : MCQ Is Question Mandatory : No

Correct Marks : 4 Wrong Marks : 1

Let $y=y(x)$ be the solution of the differential equation $(x-x^3)dy=(y+yx^2-3x^4)dx$, $x > 2$.

If $y(3)=3$, then $y(4)$ is equal to :

Options :

1. 12

2. 8

3. 16

4. 4

Question Type : MCQ Is Question Mandatory : No

Correct Marks : 4 Wrong Marks : 1

The point P (a, b) undergoes the following three transformations successively :

- (a) reflection about the line $y=x$.
- (b) translation through 2 units along the positive direction of x -axis.
- (c) rotation through angle $\frac{\pi}{4}$ about the origin in the anti-clockwise direction.

If the co-ordinates of the final position of the point P are $\left(-\frac{1}{\sqrt{2}}, \frac{7}{\sqrt{2}}\right)$, then the value of

$2a+b$ is equal to :

Options :

1. 5
2. 7
3. 9
4. 13

Question Type : MCQ Is Question Mandatory : No

Correct Marks : 4 Wrong Marks : 1

A possible value of 'x', for which the ninth term in the expansion of

$$\left\{ 3^{\log_3 \sqrt{25^x - 1} + 7} + 3 \left(-\frac{1}{8} \right)^{\log_3 (5^{x-1} + 1)} \right\}^{10} \text{ in the increasing powers of } 3 \left(-\frac{1}{8} \right)^{\log_3 (5^{x-1} + 1)}$$

is equal to 180, is :

Options :

1. 0

2. 1

3. -1

4. 2

Question Type : MCQ Is Question Mandatory : No

Correct Marks : 4 Wrong Marks : 1

Let \mathbb{C} be the set of all complex numbers. Let

$$S_1 = \{z \in \mathbb{C} : |z-2| \leq 1\} \text{ and}$$

$$S_2 = \{z \in \mathbb{C} : z(1+i) + \bar{z}(1-i) \geq 4\}.$$

Then, the maximum value of $\left|z - \frac{5}{2}\right|^2$ for $z \in S_1 \cap S_2$ is equal to :

Options :

1. $\frac{3 + 2\sqrt{2}}{4}$

2. $\frac{3 + 2\sqrt{2}}{2}$

3. $\frac{5 + 2\sqrt{2}}{2}$

4. $\frac{5 + 2\sqrt{2}}{4}$

Question Type : MCQ Is Question Mandatory : No

Correct Marks : 4 Wrong Marks : 1

Let $f: (a, b) \rightarrow \mathbf{R}$ be twice differentiable function such that $f(x) = \int_a^x g(t)dt$ for a differentiable function $g(x)$. If $f(x)=0$ has exactly five distinct roots in (a, b) , then $g(x)g'(x)=0$ has at least :

Options :

1. three roots in (a, b)
2. five roots in (a, b)
3. seven roots in (a, b)
4. twelve roots in (a, b)

Question Type : MCQ Is Question Mandatory : No

Correct Marks : 4 Wrong Marks : 1

Let A and B be two 3×3 real matrices such that $(A^2 - B^2)$ is invertible matrix. If $A^5 = B^5$ and $A^3B^2 = A^2B^3$, then the value of the determinant of the matrix $A^3 + B^3$ is equal to :

Options :

1. 0
2. 1
3. 2

4. 4

Question Type : MCQ Is Question Mandatory : No

Correct Marks : 4 Wrong Marks : 1

Let \mathbf{N} be the set of natural numbers and a relation \mathbf{R} on \mathbf{N} be defined by

$\mathbf{R} = \{(x, y) \in \mathbf{N} \times \mathbf{N} : x^3 - 3x^2y - xy^2 + 3y^3 = 0\}$. Then the relation \mathbf{R} is :

Options :

1. reflexive and symmetric, but not transitive
2. reflexive but neither symmetric nor transitive
3. symmetric but neither reflexive nor transitive
4. an equivalence relation

Question Type : MCQ Is Question Mandatory : No

Correct Marks : 4 Wrong Marks : 1

Let $\alpha = \max_{x \in \mathbf{R}} \{8^{2\sin 3x} \cdot 4^{4\cos 3x}\}$ and $\beta = \min_{x \in \mathbf{R}} \{8^{2\sin 3x} \cdot 4^{4\cos 3x}\}$.

If $8x^2 + bx + c = 0$ is a quadratic equation whose roots are $\alpha^{1/5}$ and $\beta^{1/5}$, then the value of $c - b$ is equal to :

Options :

1. 42
2. 43

3. 47

4. 50

Question Type : MCQ Is Question Mandatory : No

Correct Marks : 4 Wrong Marks : 1

The value of $\lim_{x \rightarrow 0} \left(\frac{x}{\sqrt[8]{1 - \sin x} - \sqrt[8]{1 + \sin x}} \right)$ is equal to :

Options :

1. 0

2. -1

3. -4

4. 4

Question Type : MCQ Is Question Mandatory : No

Correct Marks : 4 Wrong Marks : 1

A student appeared in an examination consisting of 8 true - false type questions. The student guesses the answers with equal probability. The smallest value of n, so that the probability of

guessing at least 'n' correct answers is less than $\frac{1}{2}$, is :

Options :

1. 3

2. 4

3. 5

4. 6

Question Type : MCQ Is Question Mandatory : No

Correct Marks : 4 Wrong Marks : 1

For real numbers α and $\beta \neq 0$, if the point of intersection of the straight lines

$$\frac{x - \alpha}{1} = \frac{y - 1}{2} = \frac{z - 1}{3} \text{ and } \frac{x - 4}{\beta} = \frac{y - 6}{3} = \frac{z - 7}{3},$$

lies on the plane $x + 2y - z = 8$, then $\alpha - \beta$ is equal to :

Options :

1. 3

2. 5

3. 7

4. 9

Question Type : MCQ Is Question Mandatory : No

Correct Marks : 4 Wrong Marks : 1

If $\tan\left(\frac{\pi}{9}\right)$, x , $\tan\left(\frac{7\pi}{18}\right)$ are in arithmetic progression and $\tan\left(\frac{\pi}{9}\right)$, y , $\tan\left(\frac{5\pi}{18}\right)$ are also in

arithmetic progression, then $|x - 2y|$ is equal to :

Options :

1. 0

2. 1

3. 3

4. 4

Question Type : MCQ Is Question Mandatory : No

Correct Marks : 4 Wrong Marks : 1

Let \vec{a} , \vec{b} and \vec{c} be three vectors such that $\vec{a} = \vec{b} \times (\vec{b} \times \vec{c})$. If magnitudes of the vectors

\vec{a} , \vec{b} and \vec{c} are $\sqrt{2}$, 1 and 2 respectively and the angle between \vec{b} and \vec{c} is θ $\left(0 < \theta < \frac{\pi}{2}\right)$,

then the value of $1 + \tan \theta$ is equal to :

Options :

1. 1

2. 2

3. $\sqrt{3} + 1$

4. $\frac{\sqrt{3} + 1}{\sqrt{3}}$

Mathematics Section B

Section Id :	864351853
Section Number :	6
Section type :	Online
Mandatory or Optional :	Mandatory
Number of Questions :	10
Number of Questions to be attempted :	5
Section Marks :	20
Enable Mark as Answered Mark for Review and Clear Response :	Yes
Sub-Section Number :	1
Sub-Section Id :	8643511080
Question Shuffling Allowed :	Yes

Question Type : SA

Correct Marks : 4 Wrong Marks : 0

If the real part of the complex number $z = \frac{3 + 2i \cos \theta}{1 - 3i \cos \theta}$, $\theta \in \left(0, \frac{\pi}{2}\right)$ is zero, then the value of

$\sin^2 3\theta + \cos^2 \theta$ is equal to _____.

Response Type : Numeric

Evaluation Required For SA : Yes

Show Word Count : Yes

Answers Type : Equal

Text Areas : PlainText

Possible Answers :

1

Question Type : SA

Correct Marks : 4 Wrong Marks : 0

If $A = \begin{bmatrix} 1 & 1 & 1 \\ 0 & 1 & 1 \\ 0 & 0 & 1 \end{bmatrix}$ and $M = A + A^2 + A^3 + \dots + A^{20}$, then the sum of all the elements of the

matrix M is equal to _____.

Response Type : Numeric

Evaluation Required For SA : Yes

Show Word Count : Yes

Answers Type : Equal

Text Areas : PlainText

Possible Answers :

1

Question Type : SA

Correct Marks : 4 Wrong Marks : 0

Let n be a non-negative integer. Then the number of divisors of the form "4n+1" of the number $(10)^{10} \cdot (11)^{11} \cdot (13)^{13}$ is equal to _____.

Response Type : Numeric

Evaluation Required For SA : Yes

Show Word Count : Yes

Answers Type : Equal

Text Areas : PlainText

Possible Answers :

1

Question Type : SA

Correct Marks : 4 Wrong Marks : 0

The distance of the point P(3, 4, 4) from the point of intersection of the line joining the points Q(3, -4, -5) and R(2, -3, 1) and the plane $2x + y + z = 7$, is equal to _____.

Response Type : Numeric

Evaluation Required For SA : Yes

Show Word Count : Yes

Answers Type : Equal

Text Areas : PlainText

Possible Answers :

1

Question Type : SA

Correct Marks : 4 Wrong Marks : 0

Let $y=y(x)$ be the solution of the differential equation $dy=e^{\alpha x+y}dx$; $\alpha \in \mathbb{N}$.

If $y(\log_e 2)=\log_e 2$ and $y(0)=\log_e\left(\frac{1}{2}\right)$, then the value of α is equal to _____.

Response Type : Numeric

Evaluation Required For SA : Yes

Show Word Count : Yes

Answers Type : Equal

Text Areas : PlainText

Possible Answers :

1

Question Type : SA

Correct Marks : 4 Wrong Marks : 0

If $\int_0^\pi (\sin^3 x) e^{-\sin^2 x} dx = \alpha - \frac{\beta}{e} \int_0^1 \sqrt{t} e^t dt$, then $\alpha + \beta$ is equal to _____.

Response Type : Numeric

Evaluation Required For SA : Yes

Show Word Count : Yes

Answers Type : Equal

Text Areas : PlainText

Possible Answers :

1

Question Type : SA

Correct Marks : 4 **Wrong Marks :** 0

Let $\vec{a} = \hat{i} - \alpha\hat{j} + \beta\hat{k}$, $\vec{b} = 3\hat{i} + \beta\hat{j} - \alpha\hat{k}$ and $\vec{c} = -\alpha\hat{i} - 2\hat{j} + \hat{k}$, where α and β are

integers. If $\vec{a} \cdot \vec{b} = -1$ and $\vec{b} \cdot \vec{c} = 10$, then $(\vec{a} \times \vec{b}) \cdot \vec{c}$ is equal to _____.

Response Type : Numeric

Evaluation Required For SA : Yes

Show Word Count : Yes

Answers Type : Equal

Text Areas : PlainText

Possible Answers :

1

Question Type : SA

Correct Marks : 4 **Wrong Marks :** 0

Let E be an ellipse whose axes are parallel to the co-ordinates axes, having its center at $(3, -4)$, one focus at $(4, -4)$ and one vertex at $(5, -4)$. If $mx - y = 4$, $m > 0$ is a tangent to the ellipse E, then the value of $5m^2$ is equal to _____.

Response Type : Numeric

Evaluation Required For SA : Yes

Show Word Count : Yes

Answers Type : Equal

Text Areas : PlainText

Possible Answers :

1

Question Type : SA

Correct Marks : 4 Wrong Marks : 0

Let $A = \{n \in \mathbf{N} \mid n^2 \leq n + 10,000\}$, $B = \{3k + 1 \mid k \in \mathbf{N}\}$ and $C = \{2k \mid k \in \mathbf{N}\}$, then the sum of all the elements of the set $A \cap (B - C)$ is equal to _____.

Response Type : Numeric

Evaluation Required For SA : Yes

Show Word Count : Yes

Answers Type : Equal

Text Areas : PlainText

Possible Answers :

1

Question Type : SA

Correct Marks : 4 Wrong Marks : 0

The number of real roots of the equation $e^{4x} - e^{3x} - 4e^{2x} - e^x + 1 = 0$ is equal to _____.

Response Type : Numeric

Evaluation Required For SA : Yes

Show Word Count : Yes

Answers Type : Equal

Text Areas : PlainText

Possible Answers :

1